

## DECT-ULE Expansion Board (DU-EB) User's Manual

---

### Document Scope

The DECT-ULE Expansion Board (DU-EB) provides dual-mode (voice and packet data) ULE Device connectivity. It features the DHAN-J DECT-ULE radio module.

This document will detail how to power up the DU-EB, how to communicate with it via UART and how its buttons and LEDs interconnect with the DHAN-J and the outside world via its Arduino R3 interface. Refer to DSP Group Developer webpage (<https://www.dspg.com/developers>) for documents describing how to use the DU-EB as an evaluation platform as well as how to use it as an application host development tool. The Developer webpage also includes the complete schematic/layout database for the DU-EB.

### Features

- Operates 1.9GHz frequency bands allocated by regulatory bodies (FCC Part15.239, ETSI EN300175, ARIB STD T101) exclusively to DECT-ULE protocol compliant devices. The DHAN-J has FCC and ETSI regulatory approval – see DSP Group Product webpage for approval documentation
- Includes DHAN-J SMT radio module with on-board antenna. see DSP Group Product webpage for module Data Sheet
- Easily configurable (jumpers) for power supplied by USB, Battery or from the 3.3V pin at CN6 on the Arduino interface
- Configurable (resistor jumpers) for routing of DHAN-J UART Rx/Tx to available pins on the Nucleo or Arduino development platform
- Firmware on the DHAN-J can be upgraded either via JTAG, USB or over the air (SUOTA) from a ULE Hub
- ULEasy reference SW is available as an extension for the STM32Cube firmware



## Table of Contents

Document Scope .....	1
Features .....	1
Table of Contents .....	2
Known Issues .....	3
Microphone and Speaker Shorting to Vcc .....	3
Device not powering up via USB Wall Plug .....	3
Expansion Board (EB) Block Diagram .....	3
DU-EB Arduino R3 Interface .....	4
Three Use Cases (Modes of Operation) .....	5
Power Supply Options .....	6
UART Routing Options .....	7
Using the DU-EB Expansion Board .....	8
Use Case 1: Application Runs on the CMND Simulator .....	8
Use Case 2: Applications Runs on External MCU (Nucleo, Arduino) .....	9
Button and LED for Application Use .....	10
Microphone and Speaker Interface .....	10
Change Log .....	11

## Known Issues

### Microphone and Speaker Shorting to Vcc

Best not to plug in the 3.5mm cable to MIC or SPK while the DU-EB is powered up – there is DC on this connector which sometimes gets shorted as the cable is plugged in.

### Device not powering up via USB Wall Plug

The USB converter on the DU-EB needs to be enumerated by the USB host before it powers the rest of the board. Therefore the DU-EB will not power up from a USB wall plug. It will power up from regular USB ports.

## Expansion Board (EB) Block Diagram

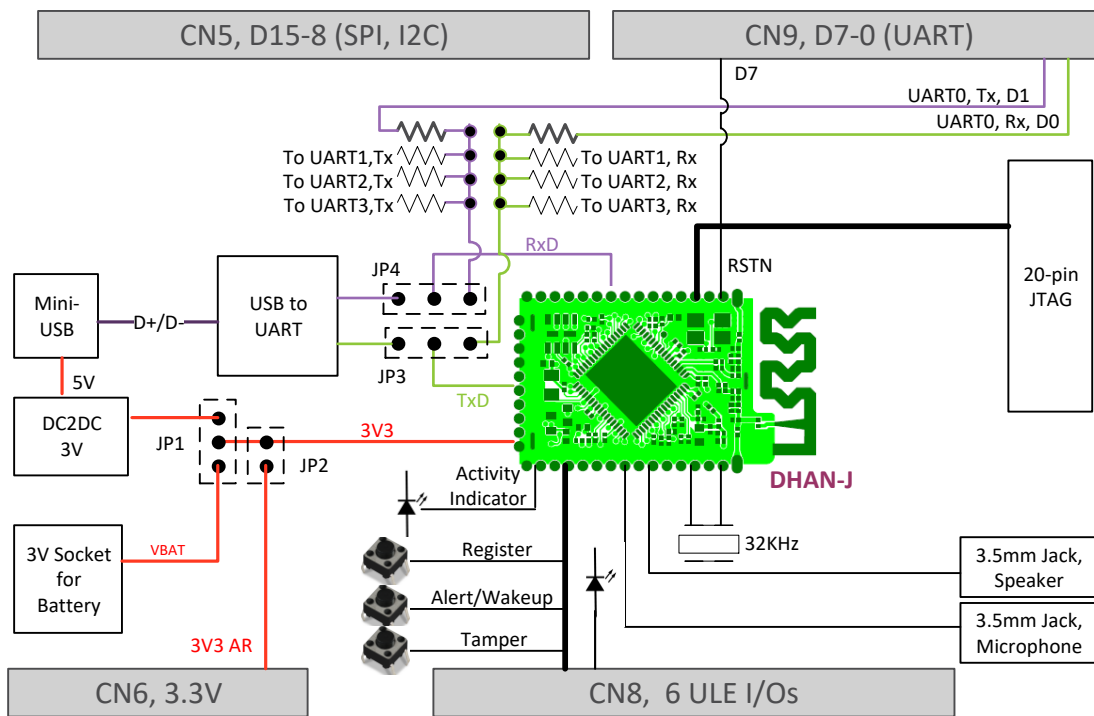

## DU-EB Arduino R3 Interface

Connector	Pin	Pin Name	DU-EB/ DHAN-J Pin Name	DU-EB/DHAN-J Function
CN6 Power On Left side	1	NC	Not Connected	
	2	IOREF	Not Connected	
	3	RESET	Not Connected	
	4	3.3V	3.3V	See Power Supply Options
	5	5V	Not Connected	
	6	GND	GND	
	7	GND	GND	
	8	Vin	Not Connected	
CN8 Analog	1	A0	ULE_IO5(DOUB2CAP)	SW2 (Button) shorts pin to 3.3V
	2	A1	ULE_IO6(LEDSINK2)	
	3	A2	ULE_IO4(AMP2_OUT)	SW3 (Button) shorts pin to 3.3V
	4	A3	ULE_IO3(AMP1_OUT)	Green LED Activity Indicator*
	5	A4	ULE_IO2 (ANA_IN2)	SW1 (Button) shorts it to 3.3V
	6	A5	ULE_IO1 (ANA_IN1)	
CN5Digital	10	D15	GPIO0 (SCL)	
	9	D14	GPIO1 (SDA)	
	8	AREF	Not Connected	
	7	GND	GND	
	6	D13	GPIO9 via jumper	SPICLK
	5	D12	GPIO8 or GPIO9 via jumpers	SPIDO or <a href="#">UART2_Rx</a>
	4	D11	GPIO7 or GPIO10 via jumpers	SPIDI or <a href="#">UART 2_Tx</a>
	3	D10	GPIO10 via jumper	SPICS
	2	D9	GPIO3 (IIC_ACK)	SW4 (Button) shorts it to 3.3V
	1	D8	GPIO9 (RxD) via TBD Ohm	<a href="#">UART 1_Rx</a>
CN9 Digital	8	D7	RSTN via 0-Ohm	
	7	D6	GPIO9 (RxD) via jumper	<a href="#">UART3_Rx</a>
	6	D5	GPIO10 (TxD) via jumper	<a href="#">UART3_Tx</a>
	5	D4	NC	
	4	D3	NC	
	3	D2	GPIO10 (TxD) via jumper	<a href="#">UART1_Tx</a>
	2	D1	GPIO9 (RxD) via jumper	<a href="#">UART0_Rx</a>
	1	D0	GPIO10 (TxD) via jumper	<a href="#">UART0_Tx</a>

\*In most SW presets for ULE

## Three Use Cases (Modes of Operation)

The DU-EB can be configured for three different modes of operation:

- 1) DU-EB as a self-contained ULE Device - The Host application runs on the DHAN-J. This mode is convenient for learning ULE protocol basics, demos and evaluating ULE range and power consumption performance. This mode, in conjunction with the JTAG interface, can also be used for developing applications directly on the DECT-ULE stack
- 2) DU-EB is a ULE Device, controlled "manually" via the CMND API by a CMND Simulator running on a PC. The PC to DU-EB connection is via a USB cable. This configuration is convenient for in-depth learning about the CMND interface. Pictured below.
- 3) DU-EB is a ULE Device and is controlled via the same CMND API by the Application Host which runs on an external MCU. The DU-EB provides an Arduino R3 connector scheme that allows it to be mounted on to 3.3V development platforms such as an Arduino M0 and Nucleo (STM32). This configuration is helpful in developing and debugging application SW for a ULE Device. Pictured below

The DU-EB ships with firmware that employs Modes 2 and 3 – refer to ULE Getting Started document in Getting Started SW package from the DSP Group website (<https://www.dspg.com/wpdm-package/gettingstarted-ule>).

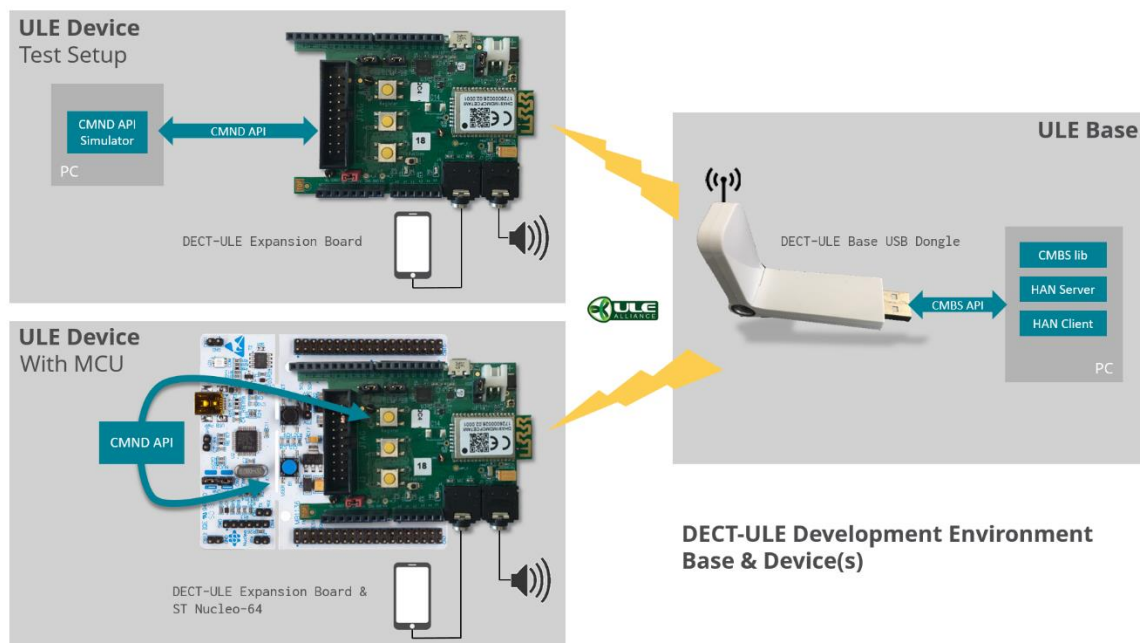

## Power Supply Options

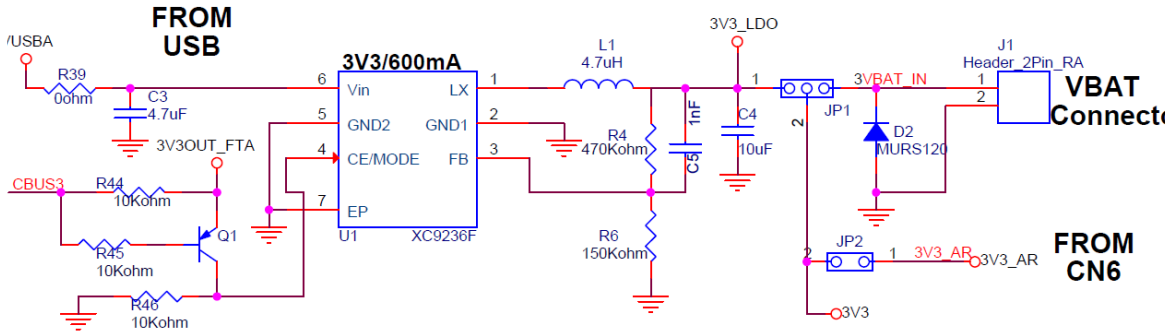

The 3.3V powering the DU-EB can be supplied from one of 3 sources:

- 1) 3V battery (or Power Supply) is plugged into the white connector (labeled J1). Header JP1 bridges between the lower pin (battery) and center pin (3.3V to DHAN-J). Header JP2 should be left open. This method of supplying power facilitates mobility and measurement of power consumption
- 2) 3V output of the DC2DC Regulator coming from the 5V on the mini-USB connector (labeled U2). Header JP1 bridges between the upper pin (labeled USB) and center pin (3.3V to DHAN-J). JP2 header is left open. This is a convenient method for working with the CMND Simulator running on the PC. This method is used in the “Getting Started” exercise (See DSP Group Developer webpage)
- 3) 3V coming FROM CN6, Pin4 and supplied by a regulator on the Nucleo or Arduino (which are powered via USB or a DC power jack). The JP2 header on the DU-EB is jumpered – see picture below. JP1 is left open.

Note: When using the Nucleo to power the DU\_EB, insure that the JP1 jumper on the Nucleo is removed to allow sufficient current drain to the DU-EB.

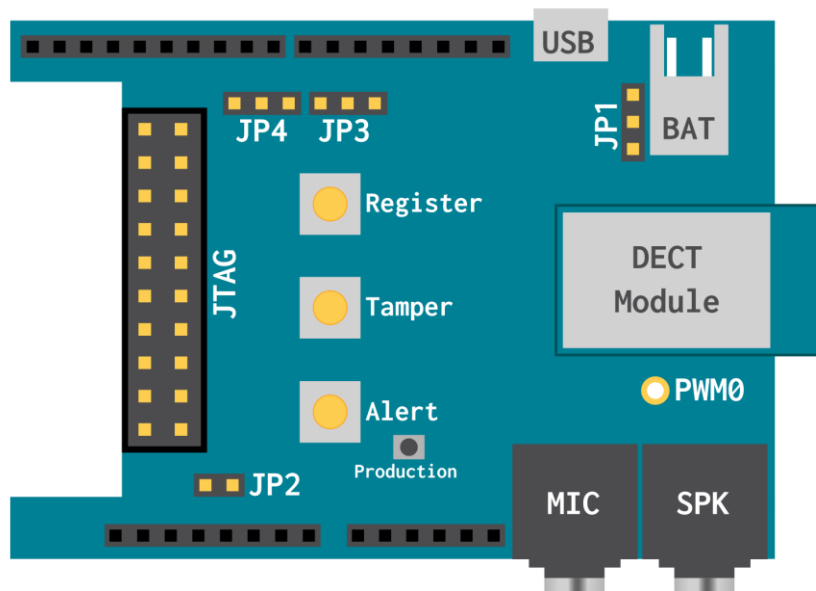

## UART Routing Options

The DHAN-J has a single, 2-pin UART interface. It can be jumpered to either the UART-USB Adaptor (for PC access with simulator or GUI) or to one of the 4 UART options at the Arduino interface – for interface with the Nucleo/Arduino or other development platforms. The tabulation below summarizes the jumpering options. Note that swapping the UART between the PC and the Development Platform is accomplished by headers JP3/JP4 only. Selecting the Arduino R3 pins for UART requires desoldering/soldering resistors - typically a “one-time” adjustment. Resistors are found on the bottom side of the DU-EB- as shown below.

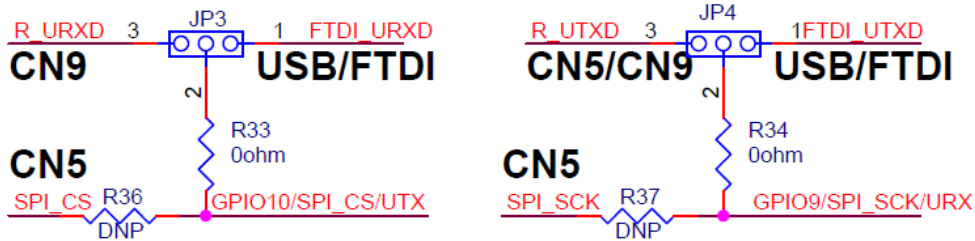

Routing Scheme	JP3	JP4	R33 /34	R18 /16	R19 /26	R28/ R27	R20 /22	R36/ 37
DU-EB UART to PC (USB)	Pin1	Pin1		DC	DC	DC	DC	DC
EB UART to UART0	Pin3	Pin3	ON	ON	OFF	OFF	OFF	OFF
EB UART to UART1 (default)	Pin3	Pin3	ON	OFF	ON	OFF	OFF	OFF
EB UART to UART2	Pin3	Pin3	ON	OFF	OFF	ON	OFF	OFF
EB UART to UART3	Pin3	Pin3	ON	OFF	OFF	OFF	ON	OFF
EB SPI_SCK, CS	DC	DC	OFF	DC	DC	DC	DC	ON

### DC= Don't Care

This default assembly (appropriate for the Nucleo) routes DHAN-J UART to Rx&Tx to Connector Pins D2 & D8 as shown below:

1	D8	GPIO9 (RxD) via TBD Ohm	UART1_Rx
3	D2	GPIO10 (TxD) via jumper	UART1_Tx

This option routes the DHAN-J UART Rx&Tx to Connector Pins D1 and D0 as shown below. This is appropriate for most Arduino boards

2	D1	GPIO9 (RxD) via jumper	UART0_Rx
1	D0	GPIO10 (TxD) via jumper	UART0_Tx

## Using the DU-EB Expansion Board

The User is encouraged to download the "ULEasy Starter Kit Pack" from the DSP Group Developer webpage. This Kit includes a tutorial stepping the User through Use Cases 1 and 2 below, the CMND simulator and ULEasy reference SW for application developers using the STM32.

### Use Case 1: Application Runs on the CMND Simulator

The DU-EB is NOT mounted on an Arduino or Nucleo – it stands alone! It is powered either by the 3.3V header (J1) or via the USB mini-connector coming from the PC – JP2 is Open. (Note: The DU-EB cannot be powered a AC switching adaptor to USB mini-connector!) Headers JP3 and JP4 should be jumpered (as shown below) to route the DHAN-J UART Tx&Rx to the FDTI UART to USB adaptor. The result is that the CMND API on the DHAN-J is presented to the CMND Simulator running on the PC. In this mode, the DHAN-J is always active (Green LED is illuminated).

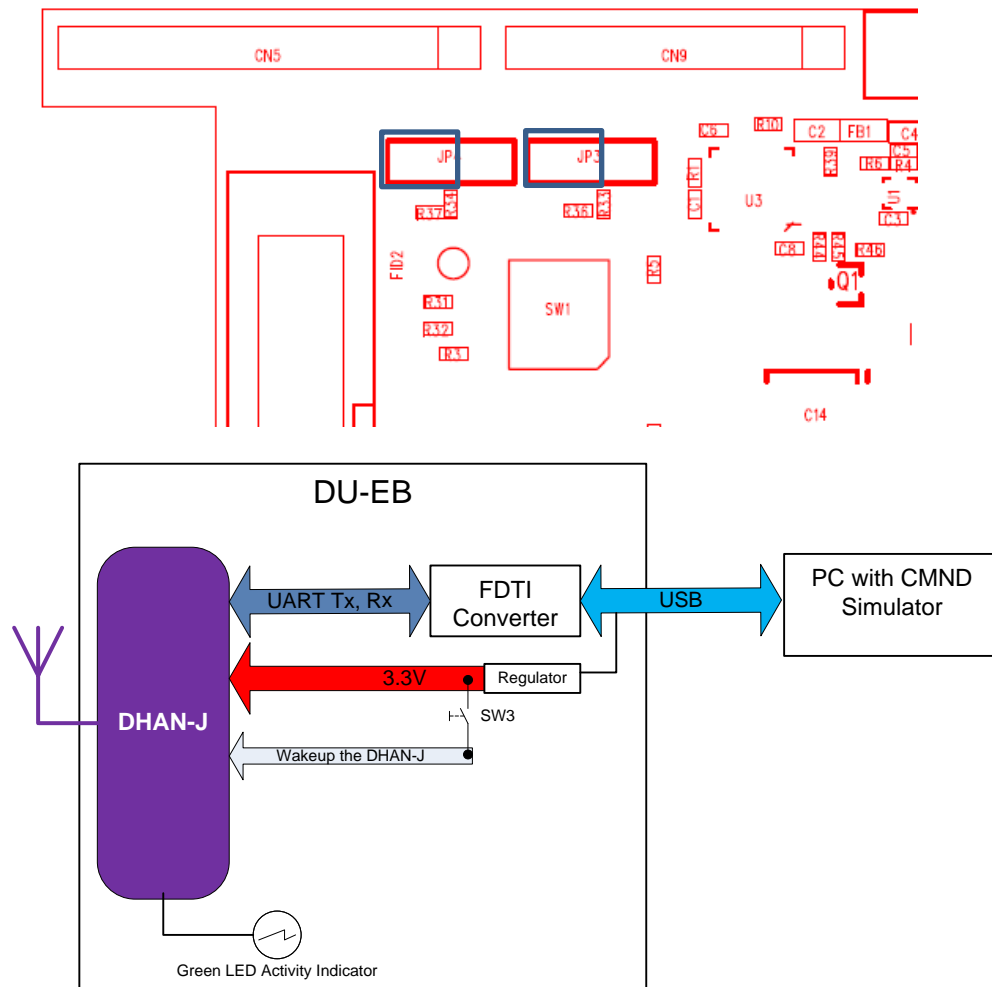



## Use Case 2: Applications Runs on External MCU (Nucleo, Arduino)

The DU-EB IS mounted on an Arduino or Nucleo. JP1 is Open, JP2 is jumpered in to provide 3.3V from the Arduino-Nucleo. The JP1 jumper on the Nucleo should be removed to allow 300mA current drain. Headers JP3 and 4 should be jumpered to route the UART Rx,Tx to the Arduino R3 CN5/9 Digital connectors.

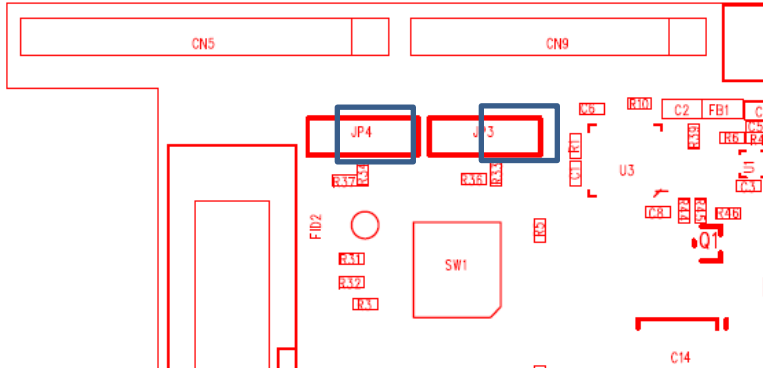

There are several options (selectable by 0-ohm resistive jumpers) for routing the UART signals to CN5/9 connectors – See previous section how to resistor jumper in these pins on the DU-EB!

Note: The default configuration on the Nucleo routes STM32 USART2 (PA2&3) to the ST-LINK MCU. That means that these pins are not available for interconnect to the DU-EB at D0&D1 /CN9. **DECT-ULE expansion SW for the STM32Cube stack activates pins PA9&10 (Arduino R3 Pins CN9/D2 and CN5/D8) for UART connection to the DU-EB.**

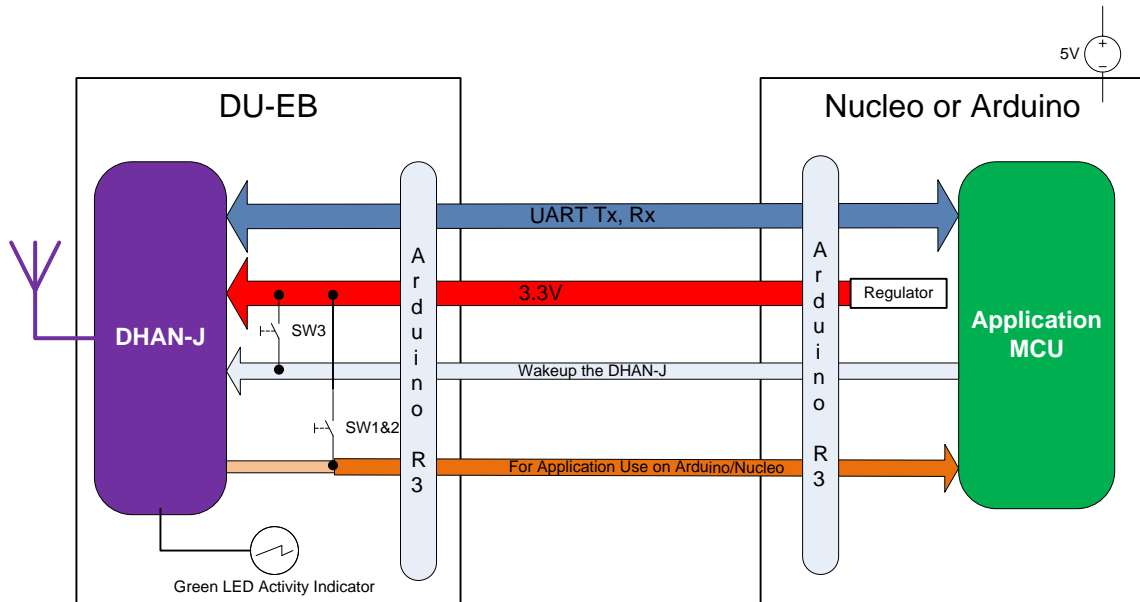

## Button and LED for Application Use

The 6 signals at CN8 run between the DHAN-J and the external MCU (Arduino or Nucleo). Most of the SW presets included in the DHAN-J SDK FW enable the green diode, D1, (connected to AMP1\_OUT to indicate that the DHAN-J is not in hibernation or in production mode. Thus, the resistor (R25) connecting AMP1\_OUT to CN8 is not placed, leaving it connected solely to the DHAN-J.

The SW in the "Getting Started" example (see Developer webpage) is configured by default to use buttons SW1, SW2 and SW3 as inputs to the FW running on the DHAN-J. Alternatively, the FW on the DHAN-J can be configured to ignore these inputs and then these buttons are available to the external MCU via CN8.

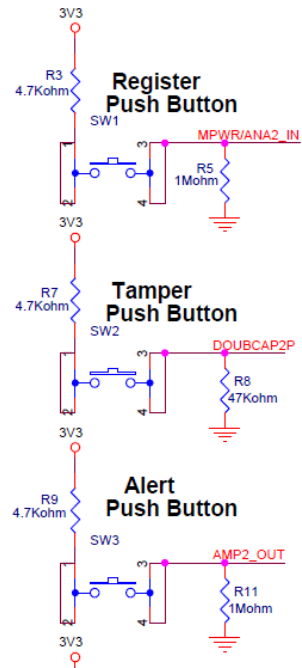
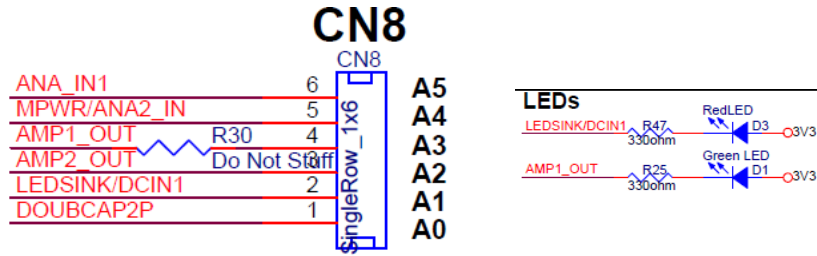

## Microphone and Speaker Interface

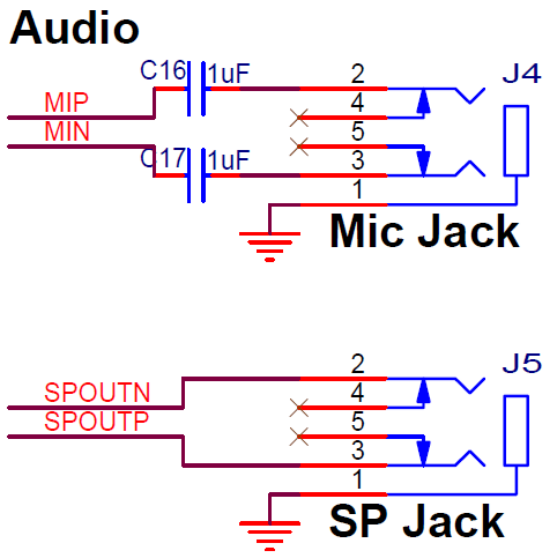

Note that the MIC feed **has been modified** from what is shown above. C16 now shunts the DHAN-J MIP pin to GND. Thus, the MIC input is now Line-In and fed by the right channel stereo connection as shown below:

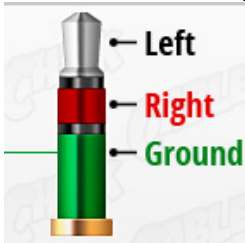

## Change Log

**Table 0-1: List of Changes**

REVISION	DATE	DESCRIPTION
2.1	November 2017	Baseline release
2.2	March 8, 2018	*Clarify Button and LED role in Use Cases *Clarify 3 Modes of Operation *Add Troubleshooting Section – MIC short, Returning to Production Mode, USB power supply
2.3	June 18, 2018	*Add FCC and ETSI regulatory approval achieved
3.0	October 17, 2018	*Align with the "Getting Started" Kit

This document is provided by DSP Group, Inc. and/or one or more of its subsidiaries ("DSP Group"). All information and data contained in this document is for informational purposes only, without any commitment on the part of DSP Group. DSP Group shall not be liable, in any event, for any claims for damages or any other remedy in any jurisdiction whatsoever, and shall not assume responsibility for patent infringements or other rights to third parties arising out of or in connection with this document. Further, DSP Group reserves the right to revise this publication and to make changes to its content, at any time, without obligation to notify any person or entity of such revision changes. These materials are copyrighted and any unauthorized use of these materials may violate copyright, trademark, and other laws. No part of this publication may be reproduced, photocopied, stored on a retrieval system, or transmitted without the express written consent of DSP Group. Any new issue of this document invalidates previous issues.

DSP Group reserves the right to revise this publication and to make changes to its content, at any time, without obligation to notify any person or entity of such revision changes.

© 2018 DSP Group. All rights reserved.

DSP Group Headquarters: 161 S San Antonio Rd, Suite 10, Los Altos CA 94022, Tel: (408)986-4300, Fax: (408)986-4323