

SP Series

Differential Low Pressure Sensors Spirometry Applications

- Highly integrated sensor with ADC and DSP
- Programmable ranges from ± 250 Pa to ± 40 kPa
- 16 bit resolution each range
- Ultra low noise, 19+ bit Effective Resolution
- Selectable Bandwidth Filter from 25Hz to 250Hz
- Z-Track™ virtually eliminates zero drift
- Very High Accuracy $\pm 0.1\%$ of Selected Range
- Long Term Stability $\pm 0.1\%$ FSS/year
- Enhanced EMI Immunity
- Output Update Rate of 500Hz
- Temperature Compensated 0°C to 50°C
- Supply Voltage Compensation
- Standard I²C and SPI Interface



Product Summary

Superior's SP Series low pressure sensor module family employs *NimbleSense*™ a proprietary architecture achieving very high dynamic range to create the industry's highest performing Spirometry pressure sensing device. This wider dynamic range is ideally suited to offer precise near zero measurements to support the demanding functional requirements of the Spirometry market. Selectable multiple pressure ranges are now supported in a single package. The SP110/SP210 can be user programmed to ± 250 , 500, 1k and 2.5k Pa full scale ranges while the SP160 is programmable to ± 5 , 10, 20 and 40 kPa ranges.

The SP Series family provides a new level of sensor integration into the Spirometry market combining an advanced piezoresistive sensing

element with integrated amplification, ADC, DSP and processor intelligence to greatly simplify customer integration efforts. The SP Series leverages floating point technology to provide a highly precise digital output. This precision, when combined with the enhanced zero point and the industry's best positional immunity enables the ultimate in Spirometry system sensing performance. The SP Series optimizes performance, reliability and system cost for the challenging Spirometry market.

Industry leading accuracy performance - The SP Series measures dry air and non-aggressive gas pressure with very high accuracy better than 0.10% FS and Total Error Band is also industry leading which is typically better than 0.15% FSS.

Table of Contents

- 1 Maximum Ratings 2
- 2 Suggested Operating Conditions 2
- 3 Environmental 2
- 4 Equivalent Circuit..... 2
- 5 Feature List 3
- 6 Performance Characteristics 3
- 7 Electrical Characteristics..... 4
 - 7.1 Supply Characteristics..... 4
 - 7.2 Reset Characteristics 4
 - 7.3 DAV Characteristics 4
 - 7.4 SPI Characteristics 5
 - 7.5 I²C Characteristics 5
- 8 Materials..... 5
 - 8.1 Wetted Materials..... 5
 - 8.2 Material Compliance 6
- 9 System Overview 6
- 10 Interface 7
 - 10.1 Reset 7
 - 10.2 Communication Interface Selection 7
 - 10.3 SPI Interface..... 7
 - 10.4 I²C Interface 8
 - 10.4.1 I²C Address 8
 - 10.4.2 I²C Communications Model 8
 - 10.4.3 I²C Clock Stretching 9
 - 10.4.4 I²C Bus Compatibility..... 9
 - 10.5 Extended Data Acquisition 9
 - 10.5.1 Available Extended Data 9
 - 10.5.2 SPI Extended Data Read 9
 - 10.5.3 I²C Extended Data Read 9
 - 10.6 Control Registers 10
 - 10.6.1 Mode Control Register 10
 - 10.6.2 Rate Control Register 11
 - 10.7 Computing Pressure 11
- 11 Mechanical and Manufacturing..... 12
 - 11.1 Package Dimensions 12
 - 11.2 Suggested Pad Layout..... 12
 - 11.3 Pinout 13
 - 11.4 Reflow Soldering and Handling Conditions 13
 - 11.5 Pick and Place Pick-up Zone 13
 - 11.6 Packaging Options 14
 - 11.6.1 Tray Packaging 14
 - 11.6.2 Tape and Reel 15
 - 11.7 Part Identification 16
- 12 Ordering Information 16
- 13 Packaging Labeling..... 16
- 14 Revisions..... 17
- 15 Warranty..... 17

1 Maximum Ratings

Parameter	Sym	Min	Max	Units
Supply Voltage	V _{DDM}	Gnd-0.3	4.0	V
Voltage on I/O Pins	V _{DD} > 3.3V	Gnd-0.3	5.8	V
	V _{DD} ≤ 3.3V	Gnd-0.3	V _{DD} +2.5	V
I/O Current	I _{IOM}	-25	25	mA

2 Suggested Operating Conditions

Parameter	Sym	Min	Max	Units
Supply Voltage	V _{DDOP}	2.8	3.5	V
Temperature	T _A	0	50	°C

3 Environmental

Parameter	Sym	Min	Max	Units	
Temperature Range	Compensated	T _{COMP}	0	50	°C
	Operating	T _{OP}	-20	85	°C
	Storage	T _{STG}	-40	85	°C
Humidity (Non-condensing)	RH _{OP}	0	95	% RH	
Vibration (10Hz-2kHz)	G _{VIBE}	-	15	g	
Shock (6 ms)	G _{SHOCK}	-	100	g	
Life	CY _{LIFE}	1M	-	Cycles	

4 Equivalent Circuit

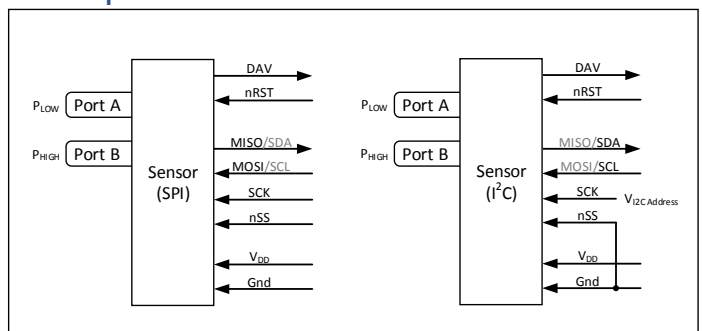

5 Feature List

Parameter	Sym	SP110	SP210	SP160	Units	Notes
Programmable FS Pressure Ranges	P _{NUM}	4			Each	
Programmable FS Range Extents	P _{EXT}	±250 to ±2.5k ±1.0 to ±10	±250 to ±2.5k ±1.0 to ±10	±5k to ±40k ±20 to ±160	Pa inH ₂ O	
Programmable BW Filter Corners	BW _{NUM}	8			Each	
BW Corner Frequency Extents	f _{BWEXT}	25 to 250			Hz	
Common Mode Pressure	P _{CM}	500	500	500	inH ₂ O	1
Proof Pressure	P _{PROOF}	40	40	1000	inH ₂ O	2
Burst Pressure	P _{BURST}	120	120	3000	inH ₂ O	3

- 1) Pressure applied to both ports simultaneously without incurring part damage.
- 2) Pressure at which the sensor will not suffer permanent damage.
- 3) Pressure if exceeded could cause permanent damage to the sensor.

6 Performance Characteristics

Note: Unless otherwise specified, characteristics specified with V_{DD} = 3.3V, T_A = 25C

Parameter	Sym	SP210			SP110			SP160			Units	Notes
		Min	Typ	Max	Min	Typ	Max	Min	Typ	Max		
Accuracy	P _{ACC}	-	-	0.1	-	-	0.1	-	-	0.1	% RNG	1
Total Error Band	TEB	-	-	0.15	-	-	0.3	-	-	0.3	% FSS	2
Long Term Stability	LTS	-	0.05	0.1	-	0.1	0.25	-	0.1	0.25	% FSS/Yr	
Thermal Hysteresis	T _{HYS}	-	0.025	-	-	0.05	-	-	0.05	-	% FSS	
Pressure Hysteresis	P _{HYS}	-	0.05	-	-	0.05	-	-	0.05	-	% RNG	1
Position Sensitivity	P _{PS}	-	0.25	-	-	2.0	-	-	2.0	-	Pa	
Supply Rejection	P _{SR}	-	0.0005	-	-	0.0005	-	-	0.005	-	Pa/mV	
Resolution	RES	-	16	-	-	16	-	-	16	-	bit	3
System ENOB	ENOB	-	18	-	-	18	-	-	18	-	Bit	4
Data Update Rate	f _{UPDATE}	485	498	512	485	498	512	485	498	512	Hz	5

- 1) Percentage of selected range.
- 2) Includes errors of offset, span and thermal effects.
- 3) Each of programmable range has the specified resolution.
- 4) ENOB stated for f_{BW} set to 25 Hz, with Z-Track™ active.
- 5) The internal update rate is fixed and does not change with range or filter settings. Sampling at lower data rates are possible provided the Nyquist frequency is observed. It is suggested to sample at least 2x the set f_{BW} frequency.

7 Electrical Characteristics

7.1 Supply Characteristics

Parameter	Sym	SP210			SP110			SP160			Units	Notes
		Min	Typ	Max	Min	Typ	Max	Min	Typ	Max		
Supply Current	I_{DD}	-	6.0	6.5	-	5.0	5.5	-	5.0	5.5	mA	
Supply Capacitance	C_{DD}	-	10	-	-	10	-	-	10	-	uF	1

1) Supply capacitance is provided within the part however it is recommended to include a 0.1 uF decoupling cap near the supply pads.

7.2 Reset Characteristics

Parameter	Sym	Condition	SP210 / SP110 / SP160			Units	Notes
			Min	Typ	Max		
Power-On Reset Threshold	V_{PORR}	Rising Voltage on V_{DD}	-	1.4	-	V	
	V_{PORF}	Falling Voltage on V_{DD}	0.75	-	1.36	V	
Interface Detect Delay	t_{IOD}	From POR or External Reset	-	-	40	ms	
First Response Settling Time	t_{FRD}	From POR or External Reset	-	-	60	ms	1
External Reset Low	t_{RSTL}		15	-	-	us	
Input High Voltage	V_{IH}		$V_{DD}-0.6$	-	-		2
Input Low Voltage	V_{IL}		-	-	0.6		2
Internal Pull-Up Current	I_{PU}	$V_{IN} = 0V$	-	-10	-30	uA	2
Input Capacitance	C_{IN}		-	7	-	pF	2

1) The filter settling time to ensure the first reading is completely settled.

2) Input nRST

7.3 DAV Characteristics

Parameter	Sym	Condition	SP210 / SP110 / SP160			Units	Notes
			Min	Typ	Max		
Output High Voltage	V_{OH}	$I_O = -3 \text{ mA}$	$V_{DD}-0.7$	-	-	V	
Output Low Voltage	V_{OL}	$I_O = 8 \text{ mA}$	-	-	0.6	V	

7.4 SPI Characteristics

Parameter	Sym	Condition	SP210 / SP110 / SP160			Units	Notes
			Min	Typ	Max		
Output High Voltage	V _{OH}	I _O = -3 mA	V _{DD} -0.7	-	-	V	1
Output Low Voltage	V _{OL}	I _O = 8 mA	-	-	0.6	V	1
Input High Voltage	V _{IH}		V _{DD} -0.6	-	-		2, 3
Input Low Voltage	V _{IL}		-	-	0.6		2, 3
Internal Pull-Up Current	I _{PU}	V _{IN} = 0V	-	-10	-30	uA	2, 3
Time nSS to First SCK Edge	t _{SC}		100	-	-	us	
Clock Cycle Time	t _{CC}		8	-	-	us	
Byte to Byte Cycle Time	t _{BC}		100	-	-	us	
Time Last Clock to nSS High	t _{CN}		20	-	-	us	
Cycle Time nSS	t _{CS}		8	-	-	us	
Input Capacitance	C _{IN}		-	7	-	pF	2

- 1) Output MOSI
- 2) Inputs MISO, SCK, nSS
- 3) Inputs are 5V compliant.

7.5 I²C Characteristics

Parameter	Sym	Condition	SP210 / SP110 / SP160			Units	Notes
			Min	Typ	Max		
SCL Clock Frequency	f _{SCL}		100	-	400	kHz	
Clock Stretch Time	t _{CKSTR}		-	15	100	us	
Input High Voltage	V _{IH}		V _{DD} -0.6	-	-		
Input Low Voltage	V _{IL}		-	-	0.6		
Output Low Voltage	V _{OL}	I _O = 8 mA	-	-	0.6	V	
Input Capacitance	C _{IO}		-	7	-	pF	

8 Materials

8.1 Wetted Materials

Parameter	Sym	SP210		SP110		SP160		Units	Notes
		P _A	P _B	P _A	P _B	P _A	P _B		
Wetted Materials	MAT _{WET}	Epoxy Nylon RTV Silicon	Epoxy Nylon RTV Silicon Gold Aluminum	Epoxy Nylon RTV Silicon	Epoxy Nylon RTV Silicon Gold Aluminum	Epoxy Nylon RTV Silicon Gold Aluminum	Epoxy Nylon RTV Silicon Gold Aluminum		

8.2 Material Compliance

Parameter	Sym	SP210		SP110		SP160		Units	Notes
		P _A	P _B	P _A	P _B	P _A	P _B		
RoHS	REG _{RoHS}	RoHS Compliant							
REACH	REG _{REAC}	REACH Compliant							

9 System Overview

The SP Series pressure sensor is a fully integrated pressure acquisition system in a sensor module. The acquisition system includes anti-alias filters, data acquisition, sensor compensation, AZ Control, noise suppression, bandwidth limiting and I/O functions. Refer to the figure below for the SP Series block diagram.



There are also two user controlled registers that tune the sensor to the specific user requirements. The first register is the Mode Control register that determines the output pressure range, the corner frequency of the bandwidth limiting filter, enables or disables the noise suppression filter and controls the Auto-Zero block with Z-Track™.

The second register is the Rate Control register which controls the rate at which the Data Available (DAV) pin is asserted. The internal sensor data update rate is 498 Hz. The Rate Control register will throttle down the rate at which the Data Available pin (DAV) is asserted by counting down from the value set in the Rate Control Register and setting the DAV pin upon reaching zero in the down counter. The DAV is reset upon each read of the pressure sensor. An internal model of the Rate Controller is illustrated in the figure to the right. In the event the Rate Control Register is set to zero, the sensor will automatically select a Rate Control Register value that is determined by the currently selected bandwidth. Refer to Section 10.6.2 for details on the rate control register functionality.



SP Series

Differential Low Pressure Sensors

10 Interface

10.1 Reset

Reset timing is shown in the diagram below.

The communications method (SPI or I²C) is established during the time just after rest. During this time (t_{IOD}), no communications should take place.

Also, the internal filters are settling during the time t_{FRD} and data acquired during this time may not be fully settled.



10.2 Communication Interface Selection

The communications interface is selected by interrogating the nSS pin after the internal power on reset delay. If nSS is high, the SPI interface will be selected otherwise (if low) the I²C interface will be selected. Grounding the nSS pin is an acceptable method for selecting the I²C interface.

10.3 SPI Interface

The SPI interface uses a 16 bit transfer for all communications. Data is MSB first for both MOSI and MISO data transfers. Refer to the figure below for specific timing requirements.

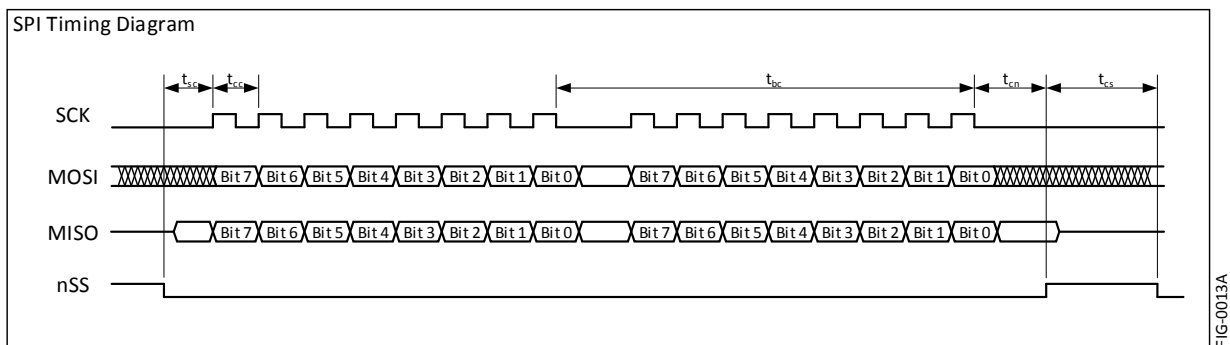

The data communications has been reduced to a simple 16 bit transfer model for reading the pressure output. Each communication cycle consists of master sending the Mode and Rate data to be placed into the sensor Mode Register and Rate Registers respectively. Simultaneously, the sensor sends the pressure data for the master to receive. Refer to the figure below for the data communication model of the SP Series sensor.

The requirement to send the Mode and Rate bytes on each data read cycle is intentional. The purpose is to force the master to send specific data for each communication and prevent inadvertent data from being sent to the sensor. Since a SPI interface will generally re-circulate data through its shift register, the intention is to prevent the pressure output from the sensor from being re-circulated back to the sensor and potentially causing unintended corruption of manufacturing data.



10.4 I²C Interface

The SP Series is compatible with the I²C protocol. For detailed information regarding the I²C protocol, please refer to the Philips I²C Bus Specification, Version 2.

10.4.1 I²C Address

R1 (kΩ)	R2 (kΩ)	Address
100	5.6	0x37
100	15	0x36
100	30	0x35
100	56	0x34
100	100	0x33
56	100	0x32
30	100	0x31
15	100	0x30
5.6	100	0x29
0	NoPop	0x28

The I²C address is set to 0x28 by grounding the SCK line. Other I²C addresses can be established by applying a voltage to the SCK line by use of a resistor divider across the sensor supply voltage. The suggested resistor values and the respective I²C address are shown in the table to the left.

Note: R1 is the lower resistor of the divider where R2 is the upper resistor of the divider.

10.4.2 I²C Communications Model

The sensor is configured as a slave device and as such, the communicating host must be configured as a master. There are two types of possible data transfers, data transfers from the master transmitter to an addressed sensor (WRITE), and data transfers from an addressed sensor to a master receiver (READ). The master device initiates both types of data transfers and provides the serial clock pulses on SCL.

The communications model for I²C is similar to that of SPI however, since I²C is a half-duplex protocol, the transfer of information to and from the sensor is separated into two separate communications. This is in contrast to the SPI interface where the transmitted and received data occurs simultaneously to and from the host. Refer to the figure to the right for the data communication model for the SP Series sensors.



10.4.3 I²C Clock Stretching

The figure to the right illustrates the I²C clock stretching by the sensor. At times, the sensor requires additional time to respond to the host and utilizes the clock stretching feature of the I²C protocol. This is accomplished by holding the SCL low after the ACK cycle of a data transfer. Refer to Section 7.5 for the clock stretching timing. Note, the maximum clock stretch time will generally only occur once during the three ACK cycles of a two byte transfer. That is, the balance of ACK's during a multi-byte transfer will generally include the typical clock stretching time.



10.4.4 I²C Bus Compatibility

The I²C specification allows any recessive voltage between 3.0 and 5.0 V. Different devices on the bus may operate at different voltage levels. However, the maximum voltage on any port pin must conform to the electrical characteristics specifications (See section 1). The bi-directional SCL (serial clock) and SDA (serial data) lines must be connected to a positive power supply voltage through a pull-up resistor or similar circuit. Every device connected to the bus must have an open-drain or open-collector output for both the SCL and SDA lines, so that both are pulled high (recessive state) when the bus is free.

10.5 Extended Data Acquisition

10.5.1 Available Extended Data

For either the SPI or I²C interface, additional data is available beyond the pressure. The means to access this extended data is to continue reading data (either SPI or I²C) beyond the first 16 bits of pressure information. The following table defines the order of the available data and respective format.

Data	Bytes	Format	Interpretation	Example
Pressure	1-2	2 byte, Signed Int	See Section 10.7	See Section 10.7
Temperature	3-4	2 byte, Signed Int	Fixed Decimal [8.8 bits], Upper 8 bits integer, lower 8 bits fractional. Temperature in °C	1880H (18.80H) = 24.5°C
Model	5-10	6 byte, ASCII, null terminated	Right reading ASCII with null termination	48H,56H,32H,31H,30H,00H = HV210
Serial Number	11-14	4 byte, Hex	Unique 4 byte serial for each part	2FD627A4H
Software Number	15-20	6 byte, ASCII, null terminated	Right reading ASCII with null termination	30H,30H,30H,33H,43H,00H = 0003C

10.5.2 SPI Extended Data Read

Reading the extended data while using the SPI interface is the same as shown in Section 10.3 with exception that the master continues to read during the same nSS sequence to read all 20 bytes of the extended data. Any portion of the 20 bytes can be read during the transfer. That is, for example, 4 bytes could be read to acquire only the pressure and temperature information. When reading the extended data, only the first two bytes sent to the sensor (User Mode and User Rate) are used to set the internal registers. The subsequent bytes (bytes 5 through 20) are ignored. Data read following the first 20 bytes is undefined.

10.5.3 I²C Extended Data Read

Reading the extended data via the I²C interface is similar to using the SPI interface where the master can simply continue to reading the sensor during the pressure reading transfer. The master continues Ack'ing until the number of desired bytes are read.

10.6 Control Registers

10.6.1 Mode Control Register

Default Value: 0x93

Details of the Mode Control register are illustrated in the figure to the right.

Bits 0-1 control the output pressure range.

Bits 2-4 control the BW Limit Filter.

Bit 5 enables the Auto-Zero function. Upon the rising edge of bit 5 (writing a 1 with the prior value being a 0), the current pressure output is captured as the zero point. The detailed behavior of this zero value is determined by bit 6 (Auto-Zero Mode bit). The Auto-Zero behavior will continue while bit 5 remains set. When bit 5 returns to 0, the Auto-Zero function will be turned off and there will be no forced zero of the part output.

Bit 6 determines the specific Auto-Zero mode. It is captured on the rising edge of bit 5. If bit 6 is zero, a standard Auto-Zero is performed. If bit 6 is 1, the Z-Track mode is initiated.

Standard Auto-Zero

When the standard Auto-Zero is initiated, the current zero pressure point is captured and is subtracted from the compensated output until the Auto-Zero function is turned off.

Z-Track Mode

When the Z-Track Mode is initiated, the current zero pressure point is captured and subtracted from the compensated output. The zero point is also tracked while the pressure output is within the noise floor of the sensor. During a pressure excursion, the zero tracking is suspended until such time as the sensor output returns to the sensor noise floor. At this time, the sensor recaptures the zero point and continues tracking zero. This function remains active while the Auto-Zero Enable bit (bit 5) remains high.

Bit 7 is the Zero-Noise Suppression Enable bit. Setting this bit will cause the sensor to suppress noise around the zero pressure output value. It is beneficial to set this bit any time the Auto-Zero function is enabled.

It should also be noted that upon changing the Mode Control value, there is a one cycle latency before the new Mode Control value becomes valid. That is, the data of the communication cycle following a change to the Mode Control register will not reflect the change. It is not until the second communication cycle that the change in the Mode Control register will be reflected in the output data.



10.6.2 Rate Control Register

Default Value: 0x00

The Rate Control Register controls the rate at which the DAV pin is asserted indicating new data is available. This register is primarily used to throttle down the actual data transfer rate (when using the DAV as the trigger to sample data).

The function of this register is that it is the reload value of a data rate down-counter. The value of the Rate Control Register is the divisor of the 498 Hz internal data rate. Since a divisor of zero is not possible, a zero value will select the auto-select rate mode. In this mode, the rate is selected based on the selected bandwidth limit. The auto rate value is two times the corner frequency of the currently selected bandwidth limit in all auto selected rates.

Note: Start-up time for the sensor is approximately 60ms for the first sample to be settled. Requesting data during this time will result in invalid information. However, this start-up time can be used for configuring the Mode and Rate registers by performing a transfer with the desired Mode and Rate register values and discarding the received pressure data. After waiting the required start-up time, the sensor will respond with desired data since the Mode and Rate registers have been pre-established.

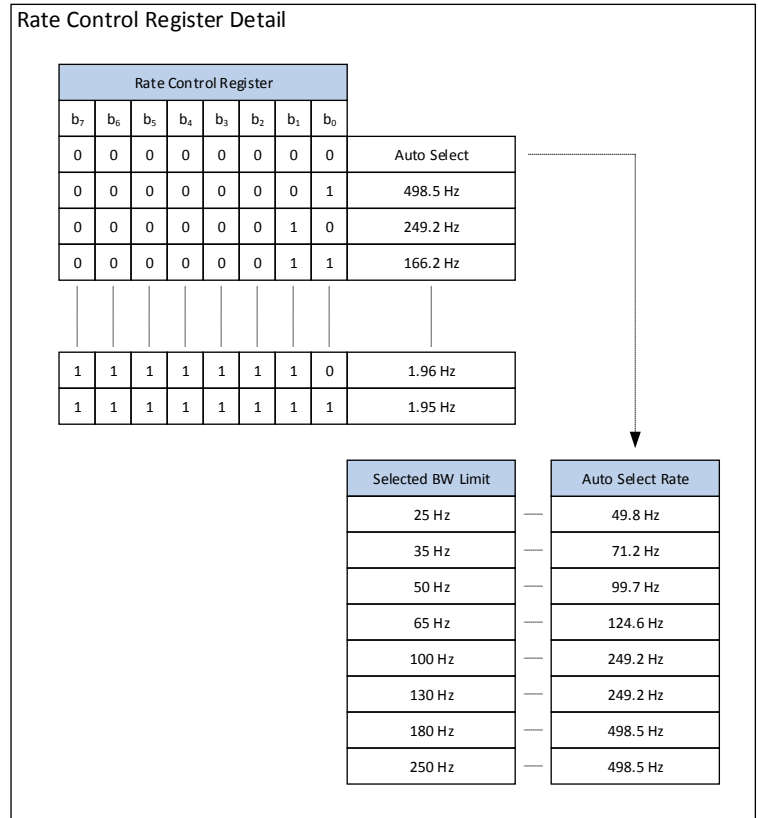

FIG-0044A

10.7 Computing Pressure

The pressure data is in the form of 16 bit signed integer sent in high byte then low byte order. This is a differential output by definition and the data range is $\pm 2^{15}$. There is a 10% margin in the output scaling and the selected full scale will reside in the 90% band of the total available output data range. Refer to Equation 1 (below) for the general model for computing the output pressure. As an example, if the sensor output is 3,647 counts and the selected pressure range is 1.0 inH₂O, then the output pressure is 0.124 inH₂O. Conversely, for a -3,647 count with the selected pressure range of 1.0 inH₂O, the computed output pressure is -0.124 inH₂O. Refer to Example 1 (below) for the specific example computation.

$$Eq\ 1: P_{inH_2O} = \frac{Out_{DIGITAL}}{90\% * 2^{15}} * Range_{SELECTED}$$

$$Example\ 1: P_{inH_2O} = \frac{3,647}{90\% * 2^{15}} * 1\ inH_2O = 0.124\ inH_2O$$

11 Mechanical and Manufacturing

11.1 Package Dimensions



11.2 Suggested Pad Layout

The suggested pad layout is shown in the figure below. An Eagle PCB symbol library is available with the shown pad dimensions. Please consult the factory to obtain the library.

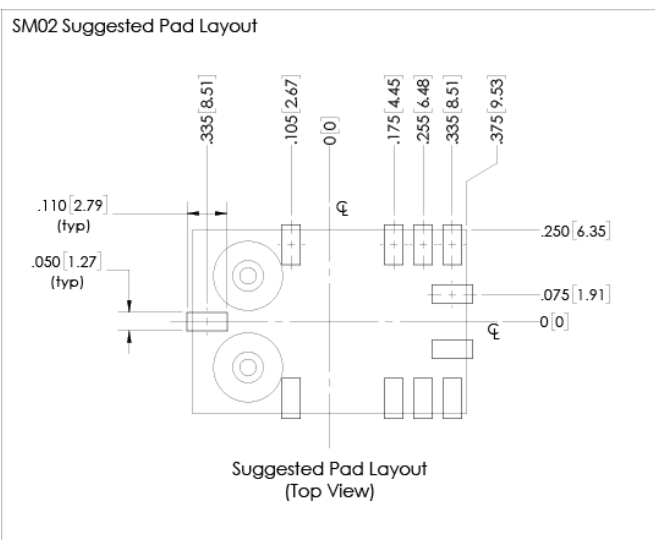

11.3 Pinout

Pin	Sym	SPI	I ² C
1	nSS	Slave Select (active low)	Tie to Ground
2	MOSI/SCL	MOSI	SCL
3	MISO/SDA	MISO	SDA
4	SCK	Serial Clock	See Section 10.4.1
5	DNC	Do Not Connect	
6	DNC	Do Not Connect	
7	DNC	Do Not Connect	
8	Gnd	Ground	
9	V _{DD}	Sensor Supply	
10	nRST	Reset (active low)	
11	DAV	Data Available	

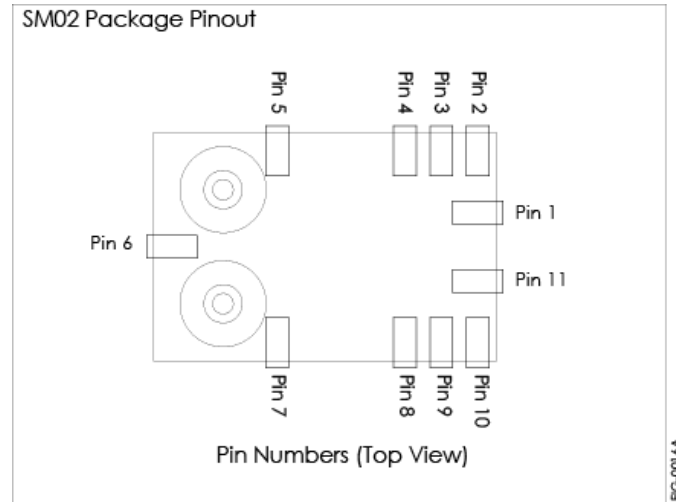

11.4 Reflow Soldering and Handling Conditions

Parameter	Sym	Val	Units
Soldering Specifications (Max)			
Preheat Ramp Rate	t _{PHRR}	3	°C/s
Soak Time	t _{SOAK}	3	min
Time Above 217C	t _{GT217}	50	s
Time Above 230C	t _{GT230}	40	s
Time Above 250C	t _{GT250}	15	s
Peak Temperature	t _{PT}	255	°C
Cooling Ramp Rate	t _{CRR}	-4	°C/s
Weight	W _{PRT}	3.5	gm
Moisture Sensitivity	MSL	3	
ESD (Human Body Model)	ESD	2	kV

11.5 Pick and Place Pick-up Zone

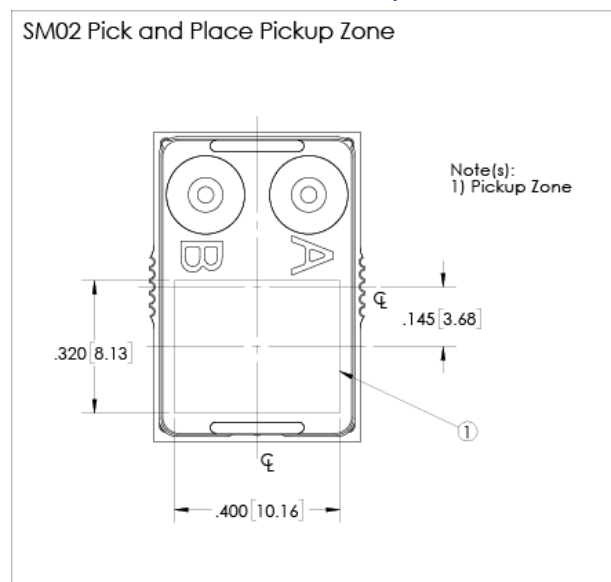

11.6 Packaging Options

11.6.1 Tray Packaging



FIG-00228

11.6.2 Tape and Reel

SM02 Tape and Reel Detail

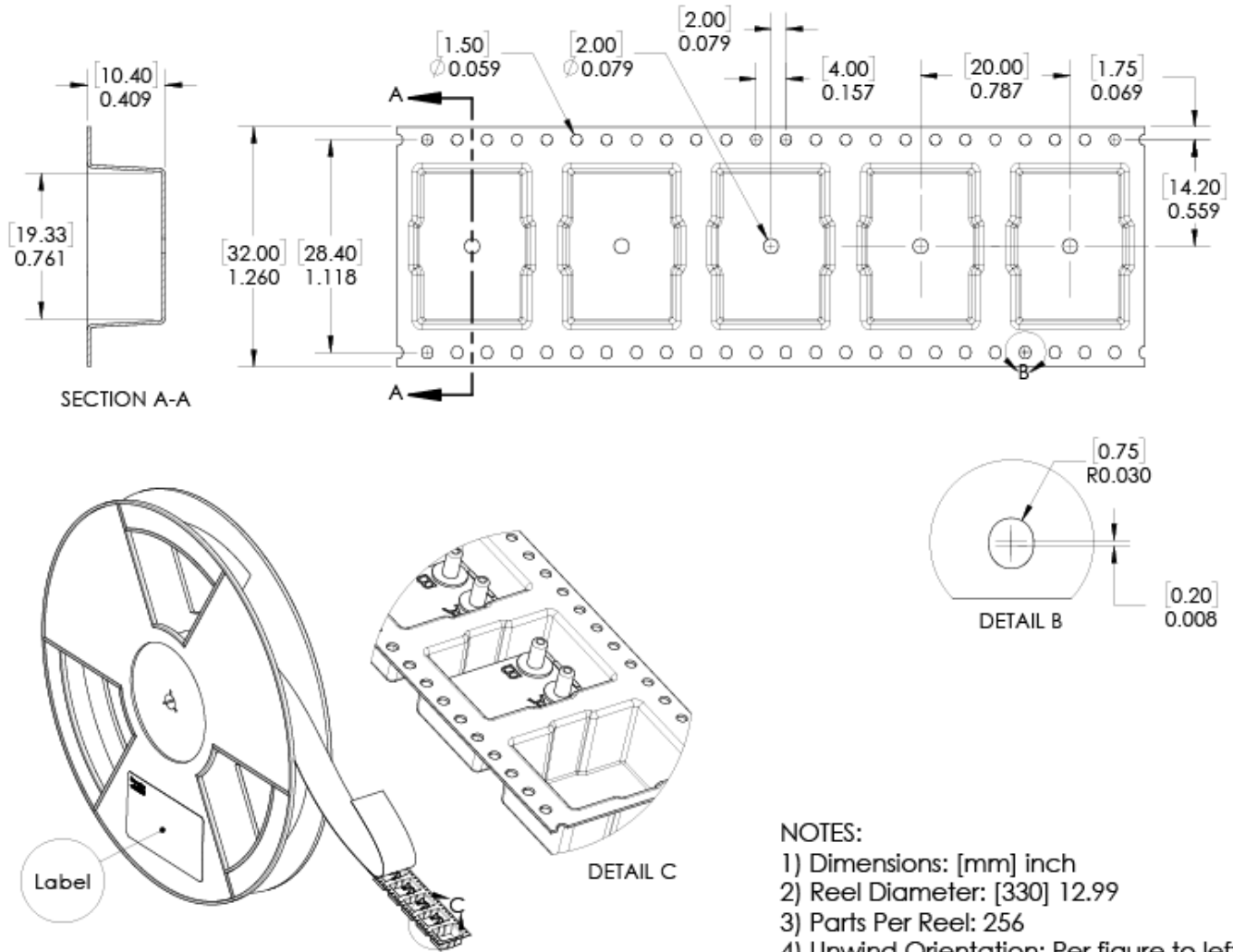

FIG-001.5A

11.7 Part Identification



12 Ordering Information

Part Number	Part Package	Packaging	Packaging Qty	Order Number
SP160-SM02	SM02	Tape and Reel	256	SP160-SM02-R
		Multi-Tray	512	SP160-SM02-M
		Single Tray	64	SP160-SM02-T
		Cut Tape	1-63	SP160-SM02-C
SP110-SM02	SM02	Tape and Reel	256	SP110-SM02-R
		Multi-Tray	512	SP110-SM02-M
		Single Tray	64	SP110-SM02-T
		Cut Tape	1-63	SP110-SM02-C
SP210-SM02	SM02	Tape and Reel	256	SP210-SM02-R
		Multi-Tray	512	SP210-SM02-M
		Single Tray	64	SP210-SM02-T
		Cut Tape	1-63	SP210-SM02-C

13 Packaging Labeling

Packaging labels are provided with barcode Code 128 symbology. The provided fields are Company Name, Part Number, Packaging ID, Quantity and Country of Origin. The Packaging ID traces back to the Lot Number (or Lot Numbers) contained in the package. The purpose is to eliminate multiple labels (one for each included Lot Number) in the event of multiple Lot Numbers within a single package. This is for ease of customer tracking and maintenance. The Packaging ID is a 24 bit value printed in hexadecimal format.



14 Revisions

Rev	Change Description(s)	Date	By
A	Initial Release	03/22/19	M.B.

15 Warranty

Superior Sensor Technology and its subsidiaries warrant goods of its manufacture as being free of defective materials and faulty workmanship during the applicable warranty period. In all cases, Superior Sensor Technology's standard product warranty applies; please refer to your order acknowledgement or consult your local sales office for specific warranty details.

If warranted goods are returned to Superior Sensor Technology during the period of coverage, Superior Sensor Technology will repair or replace, at its option, without charge those items that Superior Sensor Technology, in its sole discretion, finds defective. **The foregoing is buyer's sole remedy and is in lieu of all other warranties, expressed or implied. In no event shall Superior Sensor Technology be liable for consequential, special, or indirect damages.**

While Superior Sensor Technology may provide application assistance personally, through literature or the Superior Sensor Technology web site, it is buyer's sole responsibility to determine the suitability of the product in their application. Superior Sensor Technology assumes no liability for applications assistance or customer product design.

Superior Sensor Technology reserves the right to make corrections, modifications, enhancements, improvements and other changes to its products and services at any time and to discontinue any product or service without notice. Customers should obtain the latest relevant information before placing orders and should verify that such information is current and complete.

Superior SENSOR TECHNOLOGY

3080 Oakmead Village Road
Santa Clara, CA 95051

www.SuperiorSensors.com
info@SuperiorSensors.com
+1.408.703.2950

NimbleSense and Z-Track are trademarks of Superior Sensor Technology